

SX3HU

HCSL SURFACE MOUNT CRYSTAL CLOCK OSCILLATOR

FEATURES

- Standard miniature package
- Ultra-low jitter
- Up to 700 MHz
- Short delivery

3.2 x 2.5 x 1.0 mm

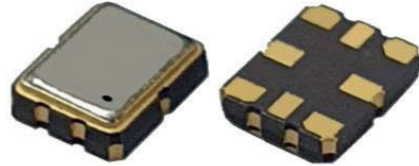

Item	Specification
Frequency Range	150.0 MHz ~ 700 MHz
Output Signal	HCSL
Overall Frequency Stability*	± 20 ppm ~ ± 100 ppm (see options)
Operating Temperature Range	0 ~ +70°C commercial application (see options) -40 ~ +85°C industrial application (see options)
Supply Voltage Vdd	+1.8V ±5% +2.5V ±10% +3.3V ±10%
Supply Current Idd	95 mA typ. ; 115 mA max
Output Voltage HIGH VOH	660 mV min. , 1.15V max.
Output Voltage LOW VOL	0 mV min. , 150 mV max.
Output Load	50 ohm to GND
Symmetry	45 / 55 %
Rise / Fall time Fr/Ff	0.40 ns max.
Tri-state function	pin #1 = high or open pin #3 ==> oscillation pin#1 = low pin #3 ==> high impedance
Start-up Time	3 ms typ. ; 10 ms max.
RMS Phase Jitter (12 kHz to 20 MHz)	150 fs typ. , 300 fs max
Packing Unit	1000pcs / reel
Soldering Condition	260°C , 10 sec x2 max

Customer specifications on request

(*) Includes initial tolerance @+25°C , stability over operating temperature , stability vs. load change , stability vs. supply change and one year aging

OPTIONS & ORDERING INFORMATION

SX3HU				Mhz
Supply Voltage *	Operating Temp. *	Overall Stability *	Tri-state Function	Frequency in MHz
18 = +1.8V 25 = +2.5V 33 = +3.3V	E = 0° / +70°C F = -20° / +70°C K = -40° / +85°C	20 = ±20 ppm 25 = ±25 ppm 30 = ±30 ppm 50 = ±50 ppm 100 = ±100 ppm	E = Tri-state	Please specify the frequency in MHz

* Note : Not all combinations are possible, please consult us.

OUTLINE DIMENSIONS (MM)

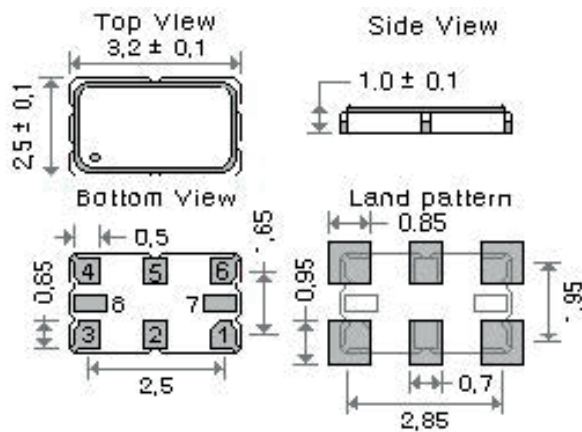

Pin Connections

#1 : E/D
#2 : NC
#3: GND
#4 : Output
#5 : Complementary output
#6 :Vdd
#7 : NC
#8 : NC