

SX3CTP

HCMOS SURFACE MOUNT TEMPERATURE COMPENSATED CRYSTAL CLOCK OSCILLATOR

FEATURES

- Miniature package
- Programmable TCXO
- One day delivery

3.2 x 2.5 x 1.7 mm

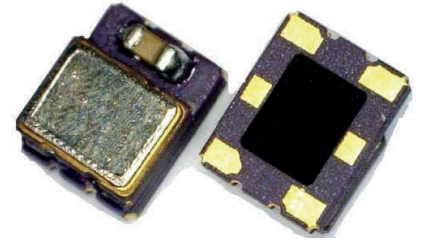

Item	Specification																														
Frequency Range	10 MHz ~ 245.0 MHz																														
Output Signal	CMOS																														
Supply Voltage V _{dd}	+2.5V ±5% +3.3V ±5%																														
Supply Current I _{dd}	30.0 mA max , Frequency dependent																														
Frequency Tolerance	±2.0 ppm at 25°C ±2°C (one hour after reflow)																														
Frequency Stability vs Temperature (see options)	<table border="1"> <thead> <tr> <th></th> <th>±0.5 ppm</th> <th>±1.0 ppm</th> <th>±1.5 ppm</th> <th>±2.0 ppm</th> <th>±2.5 ppm</th> </tr> </thead> <tbody> <tr> <td>-20° to +70°C</td> <td>○</td> <td>○</td> <td>○</td> <td>○</td> <td>○</td> </tr> <tr> <td>-30° to +75°C</td> <td>○</td> <td>○</td> <td>○</td> <td>○</td> <td>○</td> </tr> <tr> <td>-30° to +85°C</td> <td>◇</td> <td>○</td> <td>○</td> <td>○</td> <td>○</td> </tr> <tr> <td>-40° to +85°C</td> <td>×</td> <td>○</td> <td>○</td> <td>○</td> <td>○</td> </tr> </tbody> </table> <p>○ = available ◇ = please contact us × = not available</p>		±0.5 ppm	±1.0 ppm	±1.5 ppm	±2.0 ppm	±2.5 ppm	-20° to +70°C	○	○	○	○	○	-30° to +75°C	○	○	○	○	○	-30° to +85°C	◇	○	○	○	○	-40° to +85°C	×	○	○	○	○
	±0.5 ppm	±1.0 ppm	±1.5 ppm	±2.0 ppm	±2.5 ppm																										
-20° to +70°C	○	○	○	○	○																										
-30° to +75°C	○	○	○	○	○																										
-30° to +85°C	◇	○	○	○	○																										
-40° to +85°C	×	○	○	○	○																										
Frequency Stability vs Aging	±1.0 ppm max. per year at 25°C																														
Frequency Stability vs Voltage Change	±0.2 ppm max. , for a ±5% input voltage change																														
Frequency Stability vs Load Change	±0.2 ppm max. , for a ±10% load condition change																														
Output Level	VOH ≥ 0.9V _{dd} VOL ≤ 0.1 V _{dd}																														
Output Load	15 pF																														
Symmetry	45 / 55 %																														
Rise / Fall time Fr/Ff	3.0 ns max.																														
Tri-state function	<table border="0"> <tr> <td>pin #2 = high or open</td> <td>pin #4 ==> oscillation</td> </tr> <tr> <td>pin#2 = low</td> <td>pin #4 ==> high impedance</td> </tr> </table>	pin #2 = high or open	pin #4 ==> oscillation	pin#2 = low	pin #4 ==> high impedance																										
pin #2 = high or open	pin #4 ==> oscillation																														
pin#2 = low	pin #4 ==> high impedance																														
Start-up Time	5 ms max.																														
Integrated Phase Jitter (12 kHz to 20 MHz band)	1.5 ps typical																														
Packing Unit	1000pcs / reel																														
Soldering Condition	260°C , 10 sec x2 max																														

OPTIONS & ORDERING INFORMATION

SX3CTP					MHz
Supply Voltage *	Operating Temp. *	Temperature Stability *	Tri-state Function	Package type	Frequency in MHz
25 = +2.5V 33 = +3.3V	F = -20° / +70°C G = -30° / +75°C H = -30° / +85°C K = -40° / +85°C	0.5 = ±0.5 ppm 1.0 = ±1.0 ppm 1.5 = ±1.5 ppm 2.0 = ±2.0 ppm 2.5 = ±2.5 ppm	E2 = Tri-state , pin 2	6P = 6-pad version	Please specify the frequency in MHz

* Note : Not all combinations are possible , please consult us.

OUTLINE DIMENSIONS (MM)

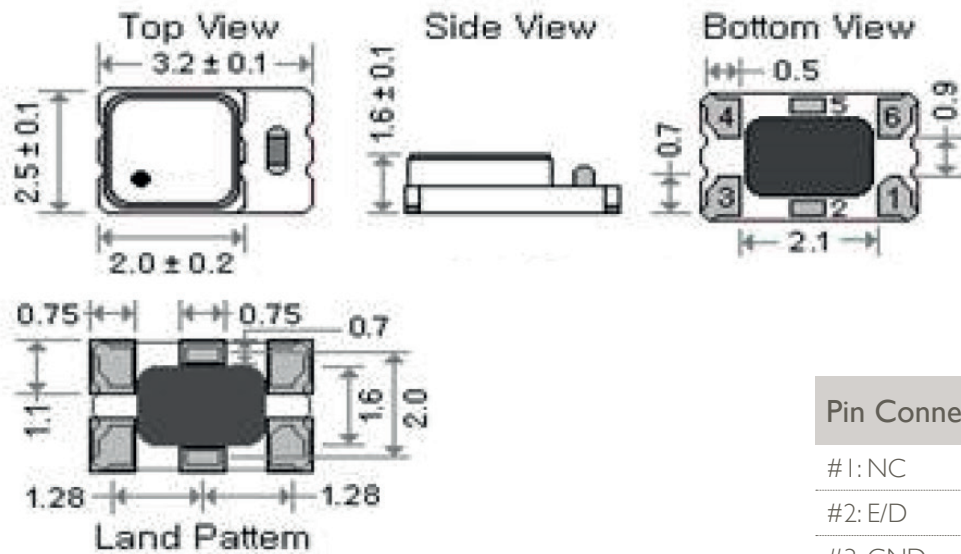

Pin Connections

- #1: NC
- #2: E/D
- #3: GND
- #4: Output
- #5: NC
- #6: Vdd